

F-4014 Series Diaphragm Amplifier

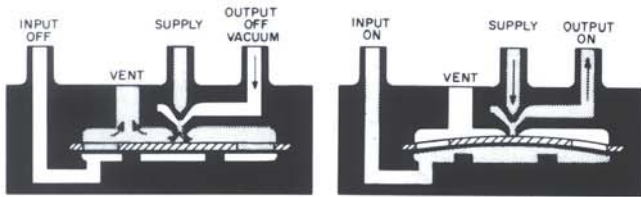

The F-4014-Series Diaphragm Amplifiers are miniature interface devices which perform the same function as a piloted three-way valve, but at low outlet flow rates. Pneumatic signals of several inches water gauge applied to the input will control the output pressure up to 35 PSI in both digital and analog systems.

Diaphragm Amplifiers are very suitable for providing pneumatic signals to air-piloted valves and for powering small cylinders. They are also used at fluidic signal levels for providing isolation and in timing circuits.



Operation

Typical Operation of the Diaphragm Amplifier

With the input signal below the actuating level, a flat spring holds the pilot diaphragm away from the opening between the output chamber and the vented chamber. A jet of supply air passes through the output chamber into the vented chamber, drawing air with it from the output chamber and causing the output pressure to be slightly negative.

With the input signal above the actuating level, the diaphragm seals the opening between the output chamber and the vented chamber. The total supply flow passes to the output port. A dead-ended load will receive the full supply pressure level with no further supply air consumption.

Inserting a restrictor into the vent port shifts the turn-on pressure to a higher value and introduces hysteresis into the characteristic. It also causes the turn-on to be snap-acting. The vent port is sized to accommodate F-2815-Series Orifice Restrictors with a press fit.

Air Logic F-4014-Series Diaphragm Amplifiers are available in five models, with either 0.012" or 0.016" diameter supply orifice and with either 3" or 8" water gauge actuating pressure. The larger supply orifice consumes more flow in the unactuated state and delivers more flow in the actuated state. (See Typical Supply Characteristics.)

For the F-4014-163 and -168 units, output flow passes through an orifice of 0.016" diameter, and exhaust flow passes through the equivalent of a 0.020" diameter orifice. For the F-4014-123 and -128 units, output flow passes through a 0.012" orifice and exhaust flow passes through the equivalent of a 0.016" orifice. Maximum output flows are shown in the Typical Supply Characteristics.

Please Read Warranty on Page 8.

FEATURES

- Fast Response
- Snap-Action
- Miniature Size

SPECIFICATIONS

Supply Flow: SEE TYPICAL SUPPLY CHARACTERISTICS
 Maximum Input Pressure: 5 PSI
 Input Leakage @ 1 PSI: Less than 0.003 SCFM
 Temperature Limits: 40° to 120°F. (4° to 49°C.)
 Recommended Filtration: 10 Micron

MATERIALS

Body: Polysulfone
 Diaphragm: Polyurethane
 Spring: Beryllium Copper

MOUNTING

Panel Mount: Two No. 6 Screws

PORT CONNECTIONS

Straight port connections for 1/16" I.D. flexible tubing

ORDERING INFORMATION (Order by model number.)

Model Number	Actuating Pressure*	Supply Orifice	Supply Pressure
F-4014-123	3" ± 2" H ₂ O	0.012"	0-35 PSI
F-4014-128	8" ± 3" H ₂ O		
F-4014-161	1" ± 1" H ₂ O	0.016"	0-25 PSI
F-4014-163	3" ± 2" H ₂ O		
F-4014-168	8" ± 3" H ₂ O		

*Input pressure for which the output pressure is one-half the supply pressure, i.e., mid span.

Input-Output Characteristics

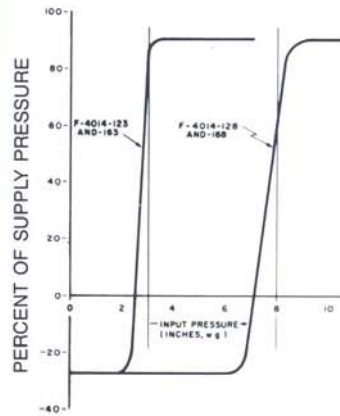

Supply Characteristics

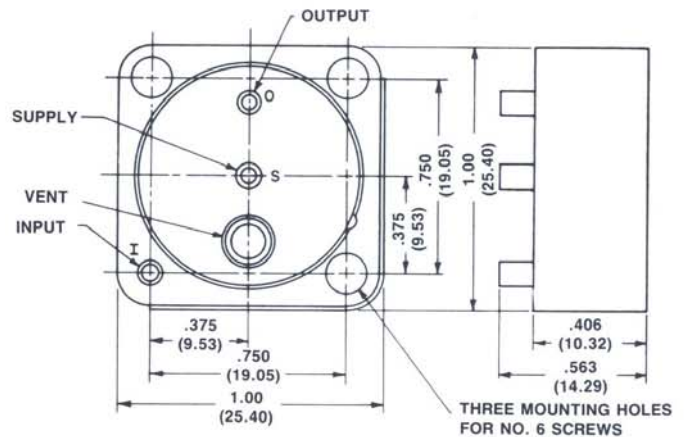
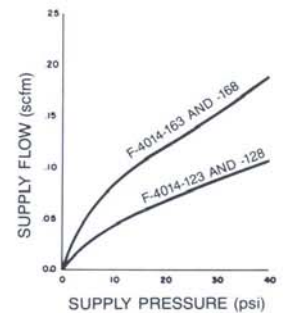

() = Metric Dimensions

Check Chemical Compatibility of Polysulfone.